

## ADJUSTABLE CONSTANT VOLUME PRIORITY DIVIDER "FG"

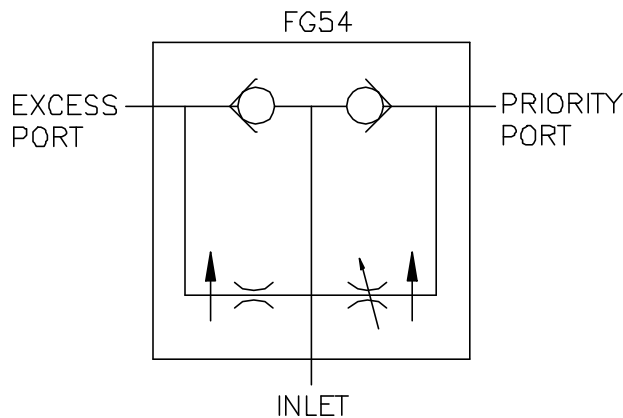
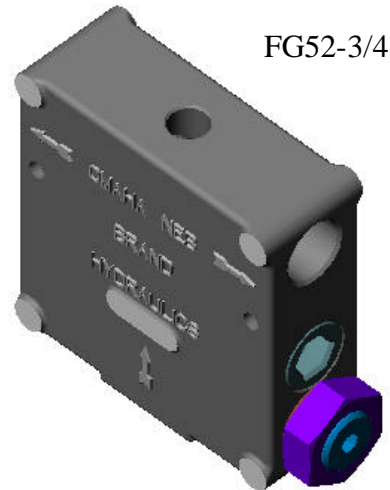
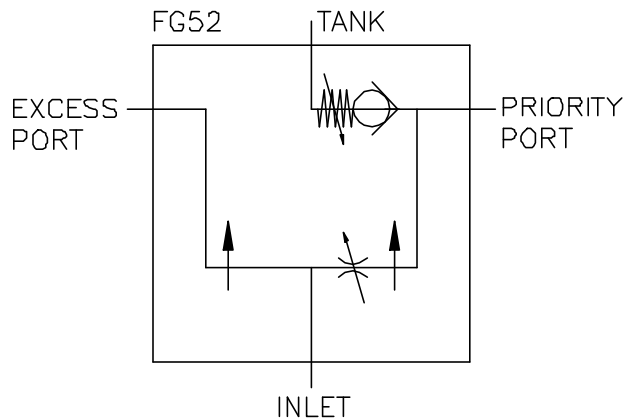

### FEATURES:

- **PRECISION GROUND HEAT TREATED SPOOL** that assures long life.
- **PRESSURE COMPENSATION** for both outlet ports.
- **EVERY FG IS TESTED** for adjustable flow and pressure compensation.
- **LARGE METERING SPOOL** provides a greater area for the pressure differential to act upon.
- **FREE REVERSE FLOW (FG54)** allows fluid to move from the outlet port to the inlet port.
- **BALL SPRING RELIEF VALVE (FG52)** for priority flow relief.

### SPECIFICATIONS:

- **Rated for 3000 psi (207 bar).**
- **Rated for 0-30 gpm (0-113.6 lpm) inlet flow.**
- **Rated for 0-15 gpm (0-56.8 lpm) priority flow.**
- **30-Micron filtration recommended.**
- **Weight -FG52, & FG54 = 8 lbs. (3.6 kg).**

### MATERIALS:

- **Cast Iron Body**
- **Buna N O'Rings**
- **Heat Treated Steel Spools**
- **Heat Treated Free Reverse Check Seat**
- **Heat Treated Relief Seat**

**FG – GENERAL INFORMATION:**

The Brand, adjustable priority flow divider comes in two basic models FG52 and FG54. The FG series receives a single stream of fluid and divides it into two separate output streams. The priority flow is adjustable from 0.2 gpm to 15 gpm with minimal pressure drop. The priority port will maintain the same flow setting even with an increase or decrease in the input flow.

**FG52** – is an adjustable priority divider with a ball spring relief for the priority port. The adjustable relief is set to 1500 psi at the factory (standard setting). The two outlet flows are pressure compensating and the sum of said flows equals the inlet flow.

**FG54** – is an adjustable priority divider with free reverse flow for both outlet ports. Flow can travel in reverse through both outlet ports and is not metered when it travels in reverse. The non-metered flow travels past the poppet, down the center of the valve, past the orifice spool and then through the inlet. The two outlet flows are pressure compensating and the sum of said flows equals the inlet flow

**FG – COMPLETE LIST OF MODEL CODES:**

**FG52-3/4**.....Adjustable priority port, 1500 psi relief setting, 3/4" NPT all ports, and 3/8" NPT tank port.

**FG54-3/4**.....Adjustable priority port, free reverse flow and 3/4" NPT all ports.

**DIMENSIONAL DATA :**

FG SHOWN:

